

C - TYPE HOSE CLAMPS According to DIN 3017

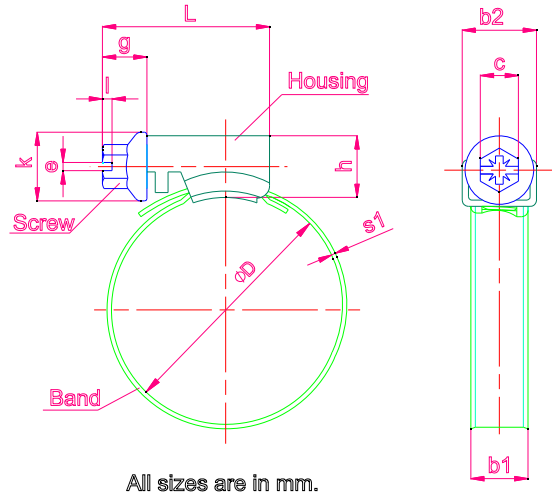

All sizes are in mm.

TABLE 1 : SIZES

| CODE NO | φ D | | L ±0.5 | s1 ±0.03 | b1 ±0.3 | c -0.1 | e ±0.1 | g ±0.3 | h +0,3 | l ±0.1 | k +0,3 -0.1 | b2 +0,3 -0.1 |
|---------|-----------|---------------|-----------|------------------|------------|------------------|-----------|-----------|-----------|-----------|-------------------|--------------------|
| | mm. | inch. | | | | | | | | | | |
| C1 - 01 | 10 - 16 | 3/8"-5/8" | 25 | 0,7 or 0,8 | 9,0 | 6,0 or 7,0 | 1,3 | 7,5 | 9,70 | 1,50 | 10,80 | 11,70 |
| C1 - 02 | (12 - 20) | 1/2"-3/4" | | | | | | | | | | |
| C1 - 03 | 12 - 22 | 1/2"-7/8" | | | | | | | | | | |
| C1 - 04 | (16 - 25) | 5/8"-1" | | | | | | | | | | |
| C1 - 05 | 16 - 27 | 5/8"-1 1/16" | | | | | | | | | | |
| C1 - 06 | 20 - 32 | 3/4"-1 1/4" | | | | | | | | | | |
| C2 - 01 | 23 - 35 | 8/9"-1 3/8" | 27 | 0,7 or 0,8 | 9,0 | 6,0 or 7,0 | 1,3 | 7,5 | 9,70 | 1,50 | 10,80 | 11,70 |
| C2 - 02 | (25 - 40) | 1"-1 5/8" | | | | | | | | | | |
| C2 - 03 | 30 - 45 | 1 1/8"-1 5/8" | | | | | | | | | | |
| C2 - 04 | 32 - 50 | 1 1/4"-2" | | | | | | | | | | |
| C2 - 05 | 40 - 60 | 1 5/8"-2 3/8" | | | | | | | | | | |
| C2 - 06 | 50 - 70 | 2"-2 3/4" | | | | | | | | | | |
| C2 - 07 | 60 - 80 | 2 3/8"-3 1/8" | | | | | | | | | | |
| C2 - 08 | 70 - 90 | 2 3/4"-3 1/2" | | | | | | | | | | |
| C2 - 09 | 80 - 100 | 3 1/8"-4" | | | | | | | | | | |
| C2 - 10 | 90 - 110 | 3 1/2"-4 3/8" | | | | | | | | | | |
| C2 - 11 | 100 - 120 | 4"-4 3/4" | | | | | | | | | | |
| C2 - 12 | 110 - 130 | 4 3/8"-5 1/8" | | | | | | | | | | |
| C2 - 13 | 120 - 140 | 4 3/4"-5 1/2" | | | | | | | | | | |
| C2 - 14 | 130 - 150 | 5 1/8"-5 7/8" | | | | | | | | | | |
| C2 - 15 | 140 - 160 | 5 1/2"-6 1/4" | | | | | | | | | | |

TABLE 2 : TORQUE

| Size φD mm | Material (Table 3) | Recommended Torque | Failure Torque |
|-------------------|----------------------------------|--------------------|----------------|
| 10-16 ... 20-32 | 1. Group 2. Group 3. Group | 4 Nm | 5 Nm |
| 20-32 ... 140-160 | 1. Group 2. Group 3. Group | 5 Nm | 6 Nm |

TABLE 3 : MATERIALS

| | |
|---|---|
| 1. Group : Band | : Material No : 1.0347 [DC03 Special Steel] |
| Housing | : Material No : 1.0330 [DC01 Special Steel] |
| Screw | : Material No : 1.0402 [20MNB4] Zinc plated through special process.] |
| Salt Spray Resistance : 72 h | |
| 2. Group : Band & Housing | : Material No : 1.4016 [(X6 Cr 17) Stainless Steel.] |
| Screw | : Material No : 1.0402 20MNB4) Zinc Plated through special process.] |
| Salt Spray Resistance : 72 h | |
| 3. Group : Band & Housing & Screw | : Material No : 1.4301 [(X5 Cr Ni 18-10) Antimagnetic Stainless Steel.] |
| Screw Head ; Upon Request : Either slotted across flats (Drawing-1) , or cross-slotted (Drawing-2). | |

*Salt Spray test is being applied according to ASTM B 117.

TABLE 4 : FREE TORQUE

| Size (mm) | Torque (Nm) |
|--------------|-------------|
| φ10 ... φ160 | max. 0,5 |

| | | | | | | | |
|---------|--------|-----------|---|----------|--|----------------------------------|--|
| | | | | | | PART NAME : | |
| | | | | | | GROUP NAME : C- TYPE HOSE CLAMPS | |
| | | | DATE NAME SIGN ÇİZEN: H.TEMİZ KONTROL: Y.POLAT ONAY: H.TEMİZ | | | MATERIAL : | |
| | | | | | | SCALE DRAWING NO | |
| | | | | | | C - 00.00 | |
| MEASURE | SYMBOL | TOLERANCE | Sheet No : | | | Quantity : same as. | |
| MEASURE | CHANGE | DATE | NAME | APPROVAL | | | |

C Type Clamps

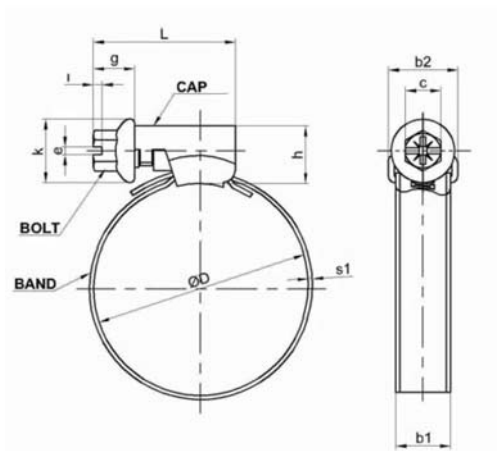

Torque Values

| Diameter ØD (mm) | Tightening Torque (Nm) | Breakdown Torque (Nm) | Idle Torque (Nm) |
|------------------|------------------------|-----------------------|------------------|
| 10-16 | 3,5 | 4 | 1 |
| 12-20 | 3,5 | 4 | 1 |
| 12-22 | 3,5 | 4 | 1 |
| 16-25 | 3,5 | 4 | 1 |
| 16-27 | 3,5 | 4 | 1 |
| 20-32 | 3,5 | 4 | 1 |
| 23-35 | 4 | 5 | 1 |
| 25-40 | 4 | 5 | 1 |
| 30-45 | 4 | 5 | 1 |
| 32-50 | 4 | 5 | 1 |
| 40-60 | 4 | 5 | 1 |
| 50-70 | 4,5 | 5 | 1 |
| 60-80 | 4,5 | 5 | 1 |
| 70-90 | 4,5 | 5 | 1 |
| 80-100 | 4,5 | 5 | 1 |
| 90-110 | 4,5 | 5 | 1 |
| 100-120 | 4,5 | 5 | 1 |
| 110-130 | 4,5 | 5 | 1 |
| 120-140 | 4,5 | 5 | 1 |
| 130-150 | 4,5 | 5 | 1 |
| 140-160 | 4,5 | 5 | 1 |

Recommended tightening speed 300 rpm.
Available for TS12091-DIN 3017

Dimensions

| Code | Ø D | | Qty in A Box | Weight of the box (kg) | L ±0.5 | s1 ±0.03 | b1 ±0.2 | c -0.1 | e ±0.1 | g ±0.3 | h ±0.3 | i ±0.1 | k ±0.3 | b2 ±0.3 | | | | | | | | | | |
|---------|---------|------------------|--------------|------------------------|--------|----------|---------|--------|--------|--------|--------|--------|--------|---------|----|-----|-----|-----|-----|-----|-----|-----|------|-------|
| | mm | inch | | | | | | | | | | | | | | | | | | | | | | |
| C1-1/01 | 10-16 | 3/8" 5/8" | 600 | 8,5 | 25 | | | | | | | | | | | | | | | | | | | |
| C1-1/02 | 12-20 | 1/2" - 3/4" | 600 | 8,8 | | | | | | | | | | | | | | | | | | | | |
| C1-1/03 | 12-22 | 1/2" - 7/8" | 600 | 8,9 | | | | | | | | | | | | | | | | | | | | |
| C1-1/04 | 16-25 | 5/8" - 1" | 600 | +9 | | | | | | | | | | | | | | | | | | | | |
| C1-1/05 | 16-27 | 5/8" - 1 1/15" | 600 | 9,1 | | | | | | | | | | | | | | | | | | | | |
| C1-1/06 | 20-32 | 3/4" - 1 1/4" | 600 | 9,2 | | | | | | | | | | | | | | | | | | | | |
| C2-2/01 | 23-35 | 8/9" - 1 3/8" | 600 | 10,4 | | | | | | | | | | | 27 | 0,7 | 9,0 | 7,0 | 1,3 | 7,5 | 9,7 | 1,5 | 10,8 | 11,70 |
| C2-2/02 | 25-40 | 1" - 1 5/8" | 600 | 11 | | | | | | | | | | | | | | | | | | | | |
| C2-2/03 | 30-45 | 1 1/16" - 1 3/4" | 300 | 5,8 | | | | | | | | | | | | | | | | | | | | |
| C2-2/04 | 32-50 | 1 1/14" - 2" | 300 | 6 | | | | | | | | | | | | | | | | | | | | |
| C2-2/05 | 40-60 | 1 5/8" - 2 3/8" | 300 | 6,5 | | | | | | | | | | | | | | | | | | | | |
| C2-2/06 | 50-70 | 2" - 2 3/4" | 160 | 3,9 | | | | | | | | | | | | | | | | | | | | |
| C2-2/07 | 60-80 | 2 3/8" - 3 1/8" | 150 | 3,9 | | | | | | | | | | | | | | | | | | | | |
| C2-2/08 | 70-90 | 2 3/4" - 3 1/2" | 130 | 3,4 | | | | | | | | | | | | | | | | | | | | |
| C2-2/09 | 80-100 | 3 1/8" - 4" | 100 | 3,8 | | | | | | | | | | | | | | | | | | | | |
| C2-2/10 | 90-110 | 3 1/2" - 4 3/8" | 90 | 2,8 | | | | | | | | | | | | | | | | | | | | |
| C2-2/11 | 100-120 | 4" - 4 3/4" | 80 | 2,7 | | | | | | | | | | | | | | | | | | | | |
| C2-2/12 | 110-130 | 4 3/8" - 5 1/8" | 70 | 2,8 | | | | | | | | | | | | | | | | | | | | |
| C2-2/13 | 120-140 | 4 3/4" - 5 1/2" | 70 | 2,9 | | | | | | | | | | | | | | | | | | | | |
| C2-2/14 | 130-150 | 5 1/8" - 5 7/8" | 60 | 2,4 | | | | | | | | | | | | | | | | | | | | |
| C2-2/15 | 140-160 | 5 1/2" - 6 1/4" | 50 | 2,2 | | | | | | | | | | | | | | | | | | | | |

Materials

| | | |
|----|-----------------|---|
| W1 | Band&Cap | : 1.0330 [DC01 (C590) Special Steel] |
| | Screw | : 1.5525 [(20MnB4) Special Zinc Plated] |
| | Salt Water Test | : 100 hours |
| W2 | Band&Cap | : 1.4016 [(X6Cr17) Magnetic st/st] |
| | Screw | : 1.5525 [(20MnB4) Special Zinc Plated] |
| | Salt Water Test | : Screw 200 hours; Band & Cap 400 hours |
| W4 | Band&Cap | : 1.4301 [(X5CrNi 18-10) Antimagnetic st/st] |
| | Screw | : 1.4567 [(X3CrNiCu 18-9-4) Antimagnetic st/st] |
| | Salt Water Test | : 800 hours |

Salt water test is performed regarding ASTM B 117 standards.

